

AU Instruction for use

POWERTEX



Lifting Point with decentered link LPD

User Manual



POWERTEX Lifting point with decentered link LPD Instruction for use (AU) (Original instructions)

Data and dimensions POWERTEX LPD - Standard

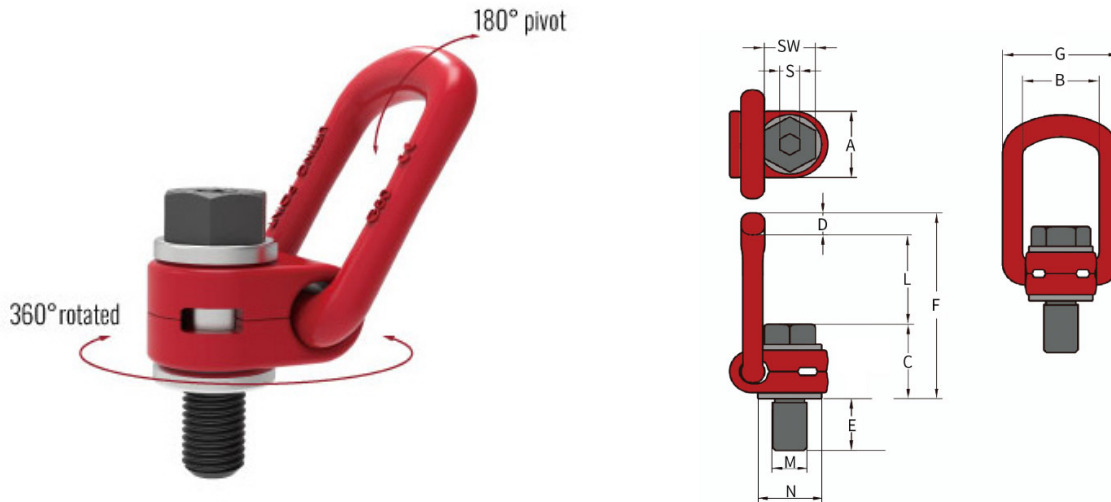

DIMENSIONS & TORQUE

Model	Thread M mm	E mm	A mm	B mm	C mm	D mm	F mm	G mm	N mm	L mm	S mm	SW mm	Torque Nm
LPD-M8	M8 x 1.25-6g	11	34	37	42	14	98.5	57	31	42,5	6	13	30
LPD-M10	M10 x 1.5-6g	16	34	37	44	14	98.5	57	31	40,5	6	16	60
LPD-M12	M12 x 1.75-6g	18	34	37	45	14	98.5	57	31	39,5	8	18	100
LPD-M16	M16 x 2.0-6g	24	34	37	48	14	98.5	57	31	36,5	10	24	150
LPD-M20	M20 x 2.5-6g	30	50	54	58	16.5	143	82	45	68,5	12	30	250
LPD-M24	M24 x 3.0-6g	36	50	54	61	16.5	143	82	45	65,5	14	36	400
LPD-M30	M30 x 3.5-6g	48	60	65	82	22	170	99	59	66	17	46	500
LPD-M36	M36 x 4.0-6g	62	77	85	104	27	226.5	123	69	95,5	22	55	800
LPD-M42	M42 x 4.5-6g	63	95	104	117	36	257.5	158	98	104,5	22	65	1500
LPD-M48	M48 x 5.0-6g	72	95	104	120	36	257.5	158	98	101,5	27	75	2000

Load diagram LPD

Working temperature -40° up to +200°C without reduction of WLL.

Australia WLL - based on AS 3776 & AS 3775 (Included angle)

Loading

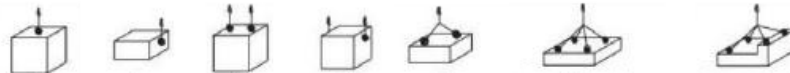

Load angle	0°	90°	0°	90°	60°	90°	120°	Asymmetric
Load factor	1.0	1.0	2.0	2.0	1.73	1.41	1.0	1.0
Model	Working Load Limit WLL (t)							
LPD-M8	0.3	0.3	0.6	0.6	0.52	0.42	0.3	0.3
LPD-M10	0.63	0.63	1.26	1.26	1.1	0.89	0.63	0.63
LPD-M12	1	1	2	2	1.73	1.4	1	1
LPD-M16	1.5	1.5	3	3	2.6	2.1	1.5	1.5
LPD-M20	2.5	2.5	5	5	4.3	3.5	2.5	2.5
LPD-M24	4	4	8	8	6.9	5.6	4	4
LPD-M30	5	5	10	10	8.6	7	5	5
LPD-M36	8	8	16	16	13.8	11.3	8	8
LPD-M42	15	15	30	30	26	21.1	15	15
LPD-M48	20	20	40	40	34.6	28.2	20	20

Data and dimensions POWERTEX LPD - Long bolt with nut

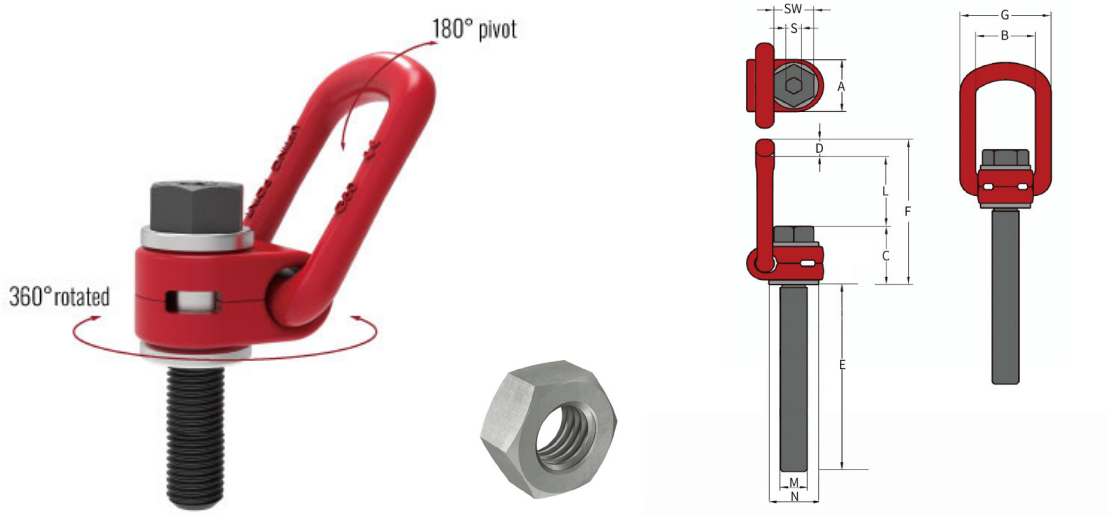

DIMENSIONS & TORQUE

Model	Thread M mm	E mm	A mm	B mm	C mm	D mm	F mm	G mm	N mm	L mm	S mm	SW mm	Torque Nm
LPD-M8	M8 x 1.25-6g	64	34	37	42	14	98.5	57	31	42,5	6	13	30
LPD-M10	M10 x 1.5-6g	80	34	37	44	14	98.5	57	31	40,5	6	16	60
LPD-M12	M12 x 1.75-6g	104	34	37	45	14	98.5	57	31	39,5	8	18	100
LPD-M16	M16 x 2.0-6g	128	34	37	48	14	98.5	57	31	36,5	10	24	150
LPD-M20	M20 x 2.5-6g	160	50	54	58	16.5	143	82	45	68,5	12	30	250
LPD-M24	M24 x 3.0-6g	192	50	54	61	16.5	143	82	45	65,5	14	36	400
LPD-M30	M30 x 3.5-6g	240	60	65	82	22	170	99	59	66	17	46	500
LPD-M36	M36 x 4.0-6g	288	77	85	104	27	226.5	123	69	95,5	22	55	800
LPD-M42	M42 x 4.5-6g	336	95	104	117	36	257.5	158	98	104,5	22	65	1500
LPD-M48	M48 x 5.0-6g	384	95	104	120	36	257.5	158	98	101,5	27	75	2000

Load diagram LPD

Working temperature -40° up to +200°C without reduction of WLL.

Australia WLL - based on AS 3776 & AS 3775 (Included angle)

Loading

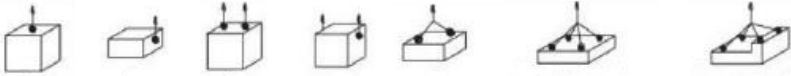

Load angle	0°	90°	0°	90°	60°	90°	120°	Asymmetric
Load factor	1.0	1.0	2.0	2.0	1.73	1.41	1.0	1.0
Model	Working Load Limit WLL (t)							
LPD-M8	0.3	0.3	0.6	0.6	0.52	0.42	0.3	0.3
LPD-M10	0.63	0.63	1.26	1.26	1.1	0.89	0.63	0.63
LPD-M12	1	1	2	2	1.73	1.4	1	1
LPD-M16	1.5	1.5	3	3	2.6	2.1	1.5	1.5
LPD-M20	2.5	2.5	5	5	4.3	3.5	2.5	2.5
LPD-M24	4	4	8	8	6.9	5.6	4	4
LPD-M30	5	5	10	10	8.6	7	5	5
LPD-M36	8	8	16	16	13.8	11.3	8	8
LPD-M42	15	15	30	30	26	21.1	15	15
LPD-M48	20	20	40	40	34.6	28.2	20	20

WARNING

The work with lifting devices and equipment must be planned, organized, and executed to prevent hazardous situations. In accordance with national statutory regulations lifting devices and equipment must only be used by someone well familiar with the work and having theoretical and practical knowledge of safe use. Before the equipment is used, the instruction manual must be read. It contains important information about how the equipment will work in a safe and correct way. Failure to follow the regulations of this instruction may cause serious consequences such as risk of injury. Apart from the instruction manual we refer to existing national regulations that may supersede these instructions.

General description

POWERTEX LPD Lifting points are intended to be used as lifting equipment to be mounted directly to the load in order to lift it or used as parts of a lifting assembly like lifting beam, lifting sling etc. LPD is not designed to rotate under load, for such applications we recommend a lifting point with ball bearing like LPB. POWERTEX LPD lifting points meet all relevant requirements of the Machinery Directive 2006/42/EC and its latest amendments and relevant requirements of EN1677-1 and AS3776.

Use in adverse environments

Temperature's effect on working load limit (WLL): Account should be taken to the temperature that can be reached in service. POWERTEX LPD lifting points can be used in temperatures between -40°C and +200°C without reduction of the working load limits.

Acidic conditions: High strength lifting components should not be used either immersed in acidic solutions or exposed to acid fumes. For same reason they must not be hot dip galvanized or exposed to electrolytic finishing without permission from the manufacturer.

Chemical affects: Consult with your distributor in case the products are to be exposed to chemicals especially combined with high temperatures.

Hazardous conditions: In particularly hazardous conditions including offshore activities, lifting of a person, and lifting of potentially dangerous loads such as molten metals, corrosive materials or fissile materials, the degree of hazard should be assessed by a competent person and the working load limit adjusted accordingly.

Use temperature range

-40 up to +200°C without reduction in WLL

+200 up to +300°C allowed with 10% reduction in WLL

+300 up to +400°C allowed with 25% reduction in WLL

Marking

POWERTEX LPD lifting points are generally marked with:

- Working Load Limit (WLL) e.g. WLL 0,3t
- Manufacturer's symbol e.g. POWERTEX or PX.
- Model name – Size e.g. LPD-M8
- Traceability code e.g. F2 (indicating a particular batch).
- Conformity marks CE + UKCA
- Bolt grade 10.9

Material and finish

POWERTEX LPD lifting points are forged from high strength alloy steel and parts are electro-static powder painted. Bolts are dacrotized to better withstand corrosion. Bolts are crack detection tested at the factory. Other load bearing parts are crack detection or proof load tested.

Selection

Select type of lifting point, thread size and working load limit suitable for the particular application. If extreme circumstances, vibrations or shock loading may occur, this must be well taken into account when selecting the correct lifting point. Through hole assembly with nut may require a longer bolt which can be ordered as spare part from your distributor. Use only original bolts which are made especially for this product.

Before first use

Ensure that the lifting points delivered corresponds to the order and that certificate and Declaration of Conformity is made available. Keep a register of all lifting equipment and make sure they are regularly checked to be fit for use.

Assembly and use

If any of these check points is not met the lifting point should not be used:

- Check that all markings are legible.
- Check there are no defects such as wear, deformation, cuts, nicks, gauges, cracks, corrosion or other visible defects that could affect the safety.

Ensure that the WLL of the lifting point is sufficient for the load to be lifted, see WLL chart. The lifting point shall be screwed tightly to the structure or load using a torque wrench. If risk of vibrations etc one should consider Loctite or other means of securing. Ensure after mounting that the lifting point can rotate and pivot freely without any obstructions in the intended angles of use. Tapped holes must be deep enough to allow the bottom of the lifting point to be supported by the contact surface. The threaded hole must be made perpendicular to the contact surface and the contact surface needs to be plane and dimensioned to accommodate the lifting point.

Recommended minimum thread lengths of different materials in relation to the metric thread diameter:

- 1 x M for steel
- 1,25 x M for cast iron
- 2 x M for aluminum alloys
- 2,5 x M for aluminum-magnesium alloys

When mounted position the link so it can be connected to directly to the lifting machine or to intermediate lifting equipment to perform the lifting operation.

Safety when lifting

Working load limit of the lifting equipment must never be exceeded. Hands and other parts of the body should be kept away to prevent injury as the slack is taken up. The load should be raised slightly without shock and a check made that it is secure and assumes the position intended. Lifting personnel must be aware of the risks of swinging and tilting loads. Never allow persons or body parts under hanging load. Do not allow persons to ride on the load while the load is being lifted. The landing site should be well prepared. It should be ensured that the ground or floor is of adequate strength to take the load. It should also be ensured that there is adequate access to the landing site and that it is clear of any unnecessary obstacles and people. The load should be landed carefully ensuring that body parts are kept clear. Ensure the stability of the load when landed before removing the lifting equipment.

Center of gravity

To avoid swinging or rotation of the load it is important to position the lifting points symmetrically above the center of gravity of the load:

- For a 1-point lift the attachment point should be arranged vertically above the center of gravity.
- For a 2-points lift the attachment points should be arranged on each side of and above the center of gravity.
- For a 3- and 4-points lift the attachment points should be arranged symmetrically in a plane around and above the center of gravity. It is preferable that the distribution should be equal and that the attachment points are above the center of gravity.

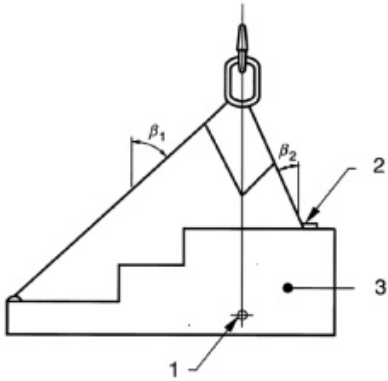

1. Centre of gravity
2. High tension in this leg
3. Load P

Load symmetry

Working load limits (WLL) for the different configurations have been determined on the basis that the loading is symmetrical. This means that when the load is lifted the lifting points are symmetrically disposed in a plane and subtend the same angles to the vertical. In the case of 2-, 3- and 4- leg chain slings, if the legs subtend different angles to the vertical the greatest tension will be in the leg with the smallest angle to the vertical. In the extreme case, if one leg is vertical, it will carry the entire load. When a sling is not symmetrically loaded each leg and lifting point shall be rated to the full load which is to be lifted, or it is considered as an engineered lift and a specialist to assess the lifting arrangement. Acc to AS3775 multileg slings shall be rated as two legs support the load and the other legs help to balance

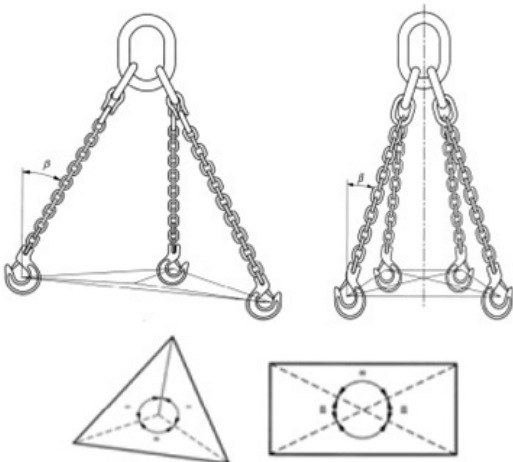

Symmetry of loading

Allowed use / Forbidden use

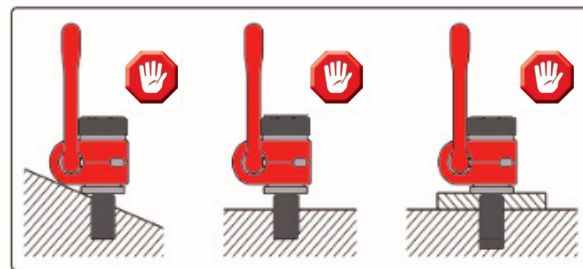
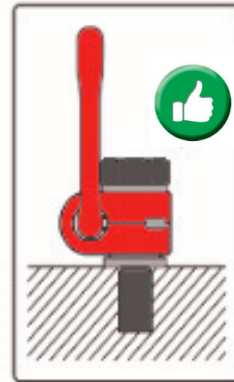
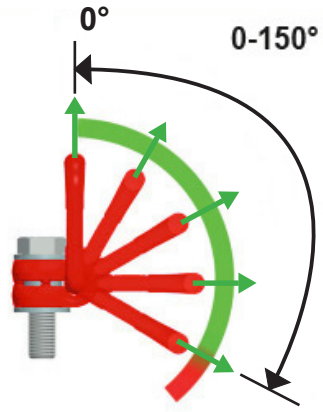
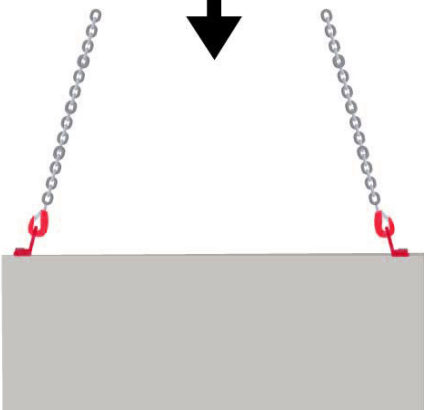
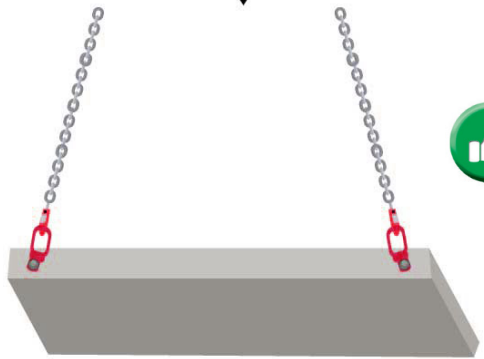
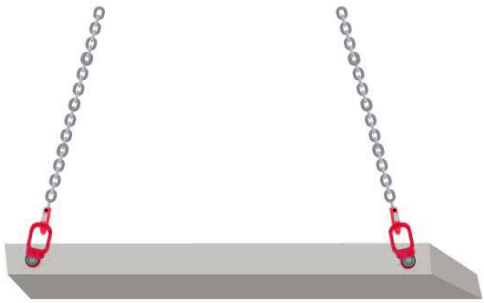

Storage of lifting points

When not in use lifting points should normally be kept on a properly designed rack. They should not be left lying on the ground where they may be damaged. If it is likely that the products will be out of use for some time they should be cleaned, dried, and protected from corrosion, e.g. lightly oiled.

Inspection and maintenance**Daily inspection**

During service the lifting points are subjected to conditions that may affect their safety. It is therefore necessary to daily check and ensure that the lifting points are safe for continued use. The lifting point should be withdrawn from service and referred to a competent person for thorough examination if any of the following is observed before each use:

- Check that all markings are legible.
- Check there are no defects such as wear, deformation, cuts, nicks, gauges, cracks, corrosion or other visible defects that could affect the safety.
- Ensure that the WLL of the lifting point is sufficient for the load to be lifted.
- Ensure that the lifting point is screwed tightly to the structure and that the lifting point can rotate and pivot freely without any obstructions in the angles of use.

Thorough examination

A thorough examination should be carried out of a competent person at intervals not exceeding twelve months. This interval should be less were deemed necessary in the light of service conditions. Records of such examinations should be maintained.

The products should be thoroughly cleaned to be free from oil, dirt and rust prior to examination. Any cleaning method which does not damage the parent metal is acceptable. Methods to avoid are those using acids, overheating, removal of metal or movement of metal which may cover cracks or surface defects.

Adequate lighting should be provided to detect any signs of wear, distortion or external damage.

Components that are worn, deformed, cracked, visibly distorted, severely corroded or have deposits which cannot be removed should be discarded and replaced. Minor damage such as nicks and gouges may be removed by careful grinding or filing. The surface should blend smoothly into the adjacent material without abrupt change of section. The complete removal of the damage should not reduce the thickness of the section at that point to less than the manufacturer's specified minimum dimensions or by more than 10% of nominal thickness of the section. Check condition of the threaded bolt.

Repair: Use only original spare parts.

End of use / Disposal

The lifting points shall be sorted / scrapped as general steel scrap.

Disclaimer

We reserve the right to modify product design, materials, specifications or instructions without prior notice and without obligation to others. If the product is modified in any way, or if it is combined with a non-compatible product/component, we take no responsibility for the consequences regarding the safety of the product.

EC Declaration of conformity

SCM Citra OY

Asessorinkatu 3-7

20780 Kaarina, Finland

www.powertex-products.com

hereby declares that POWERTEX product as described above is in compliance with EC Machinery Directive 2006/42/EC.

UK Declaration of conformity

SCM Citra OY

Asessorinkatu 3-7

20780 Kaarina, Finland

www.powertex-products.com

hereby declares that the POWERTEX product as described above is in compliance with the Supply of Machinery (Safety) Regulations 2008.

Marking

The POWERTEX lifting points LPD are **CE** and **UKCA** marked.



User Manuals

You can always find the valid and updated User Manuals on the web.
The manual is updated continuously and valid only in the latest version.

NB! The English version is the Original instruction.

The manual is available as a download under the following link:
www.powertex-products.com/manuals



Product compliance and conformity

SCM Citra OY
Asessorinkatu 3-7
20780 Kaarina
Finland
www.powertex-products.com



